

## Features

The advanced design in emergency venting for the 412 Series trailers. The #2186 exceeds the DOT HM183 vent requirements for 9/1/96 and 8/31/98. This vent has a zero release of product during an overturn, and is suitable for low pressure / vacuum applications. Full open settings are 7.5 psi for pressure and 1.0 psi vacuum. Designed for corrosion resistance to various chemicals, the #2186 uses Hastalloy springs & rods, Viton seals and corrosion resistant body material. Ideal vent for retrofitting to the Clay and Bailey #1890 manhole.



**2186**

Part No.	Size	Material	Wt.
2186-13-2400	2"	P.E.T./UHMW	1.0
2186-07-2401	2"	316 SST	6.0

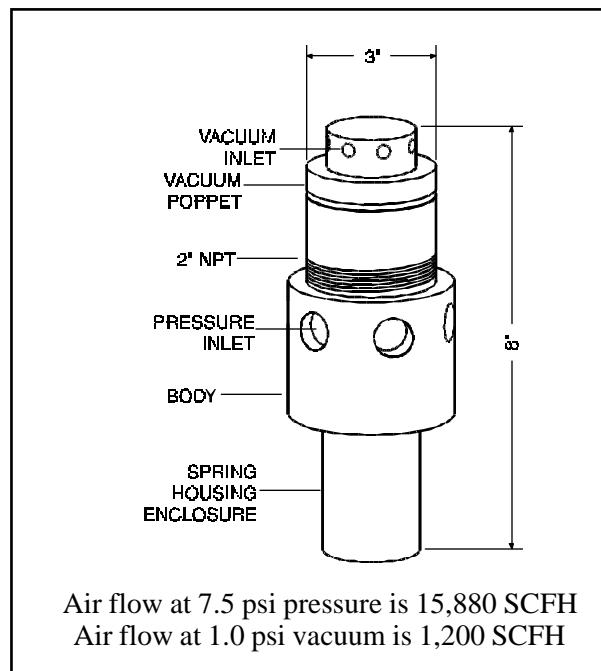

## SPECIFICATION SHEET: #2186 2" EMERGENCY VENT

**Materials:**

Corrosion Resistant Material  
Hastalloy Springs & Shaft  
Viton O-Rings & Seals

**Size:**

2" NPT, can be retrofitted to  
existing Clay & Bailey 1890  
covers

**Flow Rate:**

Pressure – Approximately  
15,880 SCFH @ 7.5 psi  
Vacuum – Approximately  
1,200 SCFH @ 1.0 psi  
vacuum

**Markings:**

As required per DOT

Clay & Bailey Mfg. Co.  
#2186

O.P. 5 psig  
15,880 SCFH @ 7.5 psi  
Vac. 0.5 psi  
1,200 SCFH @ 1.0 psi vacuum

